



Efficiency and reliability, every day!

A graphic showing a blue water splash with a single droplet in the center, creating concentric ripples. The splash is set against a white background that transitions into a blue gradient at the bottom.

BUFFER SMALL CAPACITY TANKS

Ø360 / 25-100 Lt



TECHNICAL SPECIFICATIONS

MODEL		25lt Ø360	40lt Ø360	50lt Ø360	80lt Ø360	100lt Ø360
Capacity	Lt	23.5	31	47.5	73.5	98
Test pressure	bar	12				
Max. Operational pressure	bar	8				
Expanded polyurethane insulation	mm	20				
Weight empty	kg	10	12	16	17	20
Max. Operational temperature	°C	95				

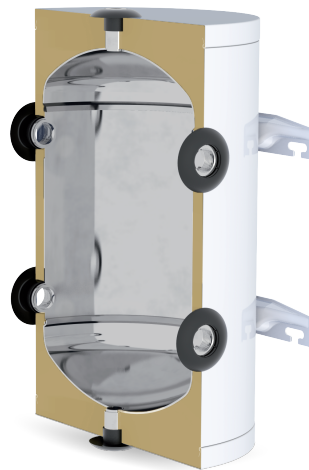

25-40-50L
2 INLETS & 2 OUTLETS

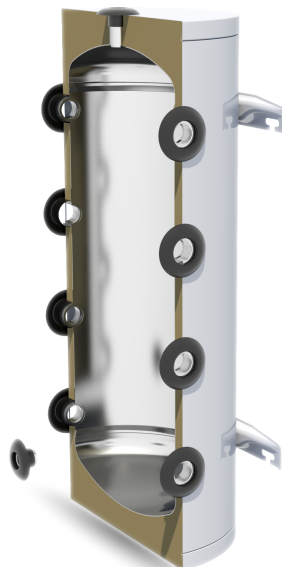

80-100L
4 INLETS & 4 OUTLETS

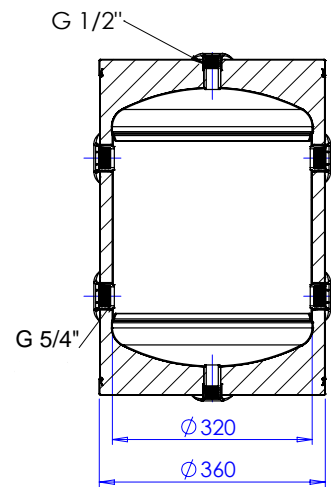
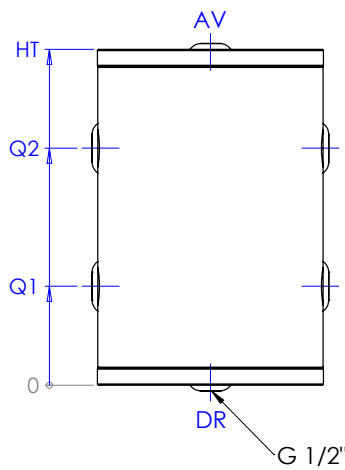
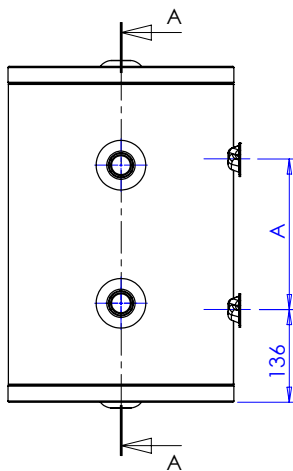

SECTION A-A

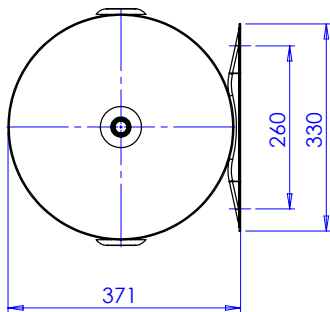

25-40-50L | 4-PIPE *Dimensions (mm)*

TYPE	A	Q1	Q2	HT
25 L	140	158	278	435
40 L	240	158	378	535
50 L	450	158	578	745

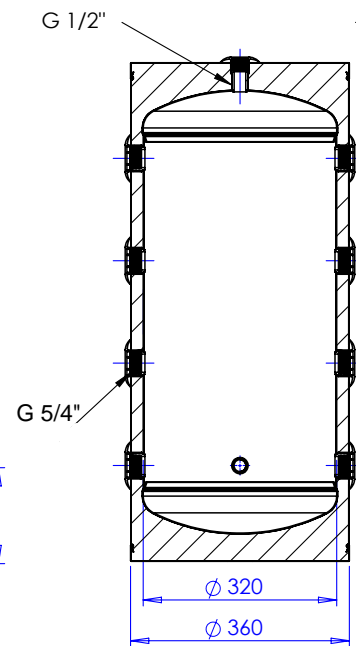
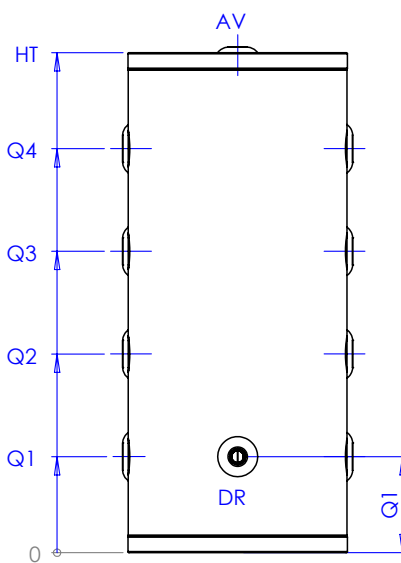
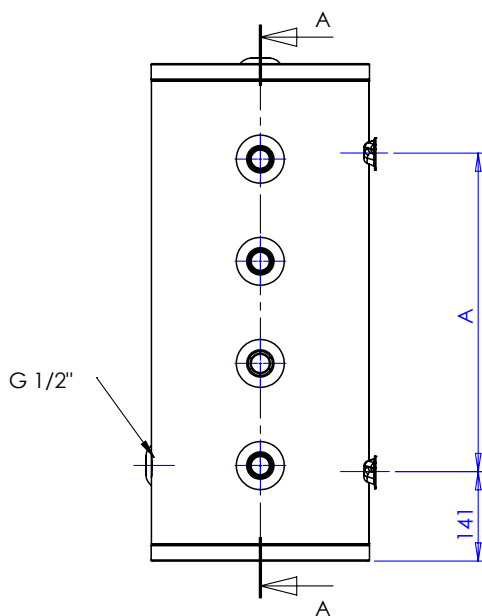

SECTION A-A

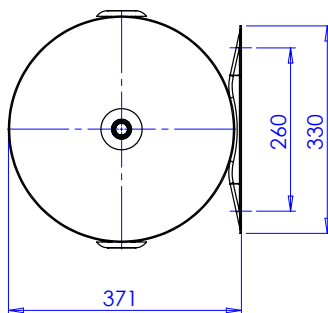

80-100L | 8-PIPE *Dimensions (mm)*

TYPE	A	Q1	Q2	Q3	Q4	HT
80 L	780	163	416	669	923	1085
100 L	1080	163	519	876	1233	1395

Efficiency and reliability, every day!

BUFFER SMALL CAPACITY TANKS

Ø360 / 25-100 Lt

NOBEL INTERNATIONAL EAD
SOLAR WATER HEATING SYSTEMS INDUSTRY

48 Vitosha Blvd., Elin Pelin 2100 - Sofia Region, Bulgaria
Tel.: +359 2 4210232 email: info@nobel.bg

www.nobel.bg

